

Leading the World in Emission Solutions



CDTi (NASDAQ:CDTI)

VERT FORUM

MARCH 2015

Catalyst/Materials

New Light Duty Vehicle (LDV) & HDD

Over 11M catalysts sold to-date



- Gasoline
- Heavy Diesel
- Light Diesel
- Natural Gas
- Biofuels



Heavy Duty Diesel (HDD) Systems

On-Road Replacement Parts, Niche OEM & Retrofit

Over 35,000 retrofit systems sold worldwide to-date

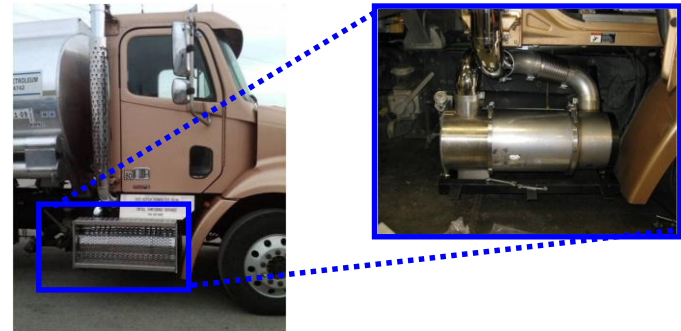

- On-Road
- Replacement Market
- Ports and Marine
- Construction & Mining
- Stationary Power





Vehicle Platforms						
						Acura ILX
				Acura RLX	Acura RLX	Acura RLX
				Accord FHEV	Accord FHEV	Accord FHEV
				Accord PHEV	Accord PHEV	Accord PHEV
Mobilio			Accord V6	Accord V6	Accord V6	Accord V6
Step Wagon	Step Wagon	Acura TSX	Acura TSX	Acura TSX	Acura TLX	Acura TLX
Fit	Accord L4	Accord L4	Accord L4	Accord L4	Accord L4	Accord L4
2001-2003	2004-2007	2008-2011	2012	2013	2014	2015

Mixed Phase Catalyst (MPC®) Technology

- Proprietary nano-structure materials platform
- Standard competitor PGM platforms are prone to sintering and loss of surface area
- Successfully deployed with global OEMs

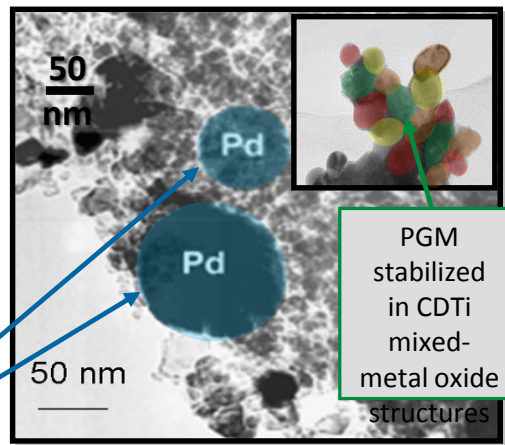

Sintered Palladium (Pd) in aged conventional catalysts

Spinel™ Technology

- Family of technologies using the Spinel structure
- Versatile class of structure with a wide range of compositional and doping possibilities
- Improved catalytic performance using substantially lower or zero use of PGM and rare earth metals

Spinel

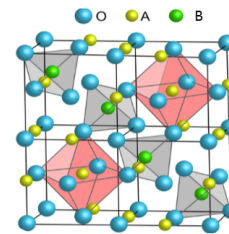

Oxygen Storage Material "OSM"

- Zero rare earth metals
- Unique oxygen storage levels

Synergized Platinum Group Metal Catalyst "SPGM™"

- Zero rare earth metals
- Enables unique catalyst activity with low PGM

Zero Platinum Group Metal Catalyst "ZPGM™"

- Zero platinum group/rare earth metals
- High catalytic activity



35 Years of Severe-Duty Emissions and Installation Experience

- Buses
- Refuse Trucks
- Long Haul & Short Haul Trucks
- Construction & Mining
- Materials Handling



















Broad Portfolio of Emissions Products

- OEM
- Retrofit
- Aftermarket



APPLYING EMISSION CONTROL TECHNOLOGY TO REDUCE HD DIESEL EMISSIONS

Agency	Purifilter EGR	Purifilter	Purifilter Plus	Combifilter
VERT	 VERT VFT3 in progress	 VERT B133/04.03		 VERT B049/05.98 & B119/11.02
United States	 US EPA	 US EPA	 US EPA	
California	 CARB	 CARB	 CARB	 CARB
United Kingdom	 UK-TfL	 UK-VCA		
Italy	 LEZ			
Sweden		 MTC-LEZ		 MTC-LEZ
Denmark		 DK-LEZ		 DK-LEZ

Year	Program or Application	What	How Many
1993-4	Chilean Bus Retrofit Program	DZ Purifier™ (DOC's)	>1000 units
1996-2002	US EPA urban bus retrofit / rebuild program	Direct Fit AZ Purimuffler® DOC's	>10,000 units
2000 onwards	US EPA Voluntary Retrofit Program - First program verifications	AZ Purifier™ & Puimuffler® DOC's	>20,000 units
Fall 2004 to Spring 2005	LA, LA County, Pasadena, Long Beach Public Works Trucks	Purifilter® DPF's	324 units
2008-2009	Port of Oakland Class 8 drayage truck	Purifilter® and Purifilter® Plus DPF's	>600 units
2012-2013	London Low Emissions Zone Program for LD commercial and Heavy Goods vehicles	Purifier™ e4 DPF systems -marketed as Purifilter® EGR in North America	3598 units
2011-14	State of New Jersey DOT fleet	Purifilter® Plus DPF's	>850 units

- **Passively Regenerating DPF Technology**
 - **25% of duty cycle >280°C**
 - **Compact catalyzed DPF**
- **VERT Verified in 2003**
- **1st Verified DPF in North America with Silicon Carbide Substrate (2003)**
- **1st DPF Verified at 90% PM Reduction Level by US EPA**
 - **HC: 85%, CO:75%**



- **Passively Regenerating DPF with Active Regeneration via Periodic Plug-In**
 - No duty cycle requirement
 - No modification of vehicle fuel system
- **Allows Vehicle Operation over Cold or Variable Driving Conditions**
- **Ideal for Captive Fleets**
 - Buses, refuse trucks and public fleet vehicles
 - Active regeneration takes 3hrs
 - Reduces need for DPF centerbody removal



- **Passively Regenerating DPF Technology**
 - 30% of duty cycle >240°C
 - MPC® precious metal coating on Diesel Oxidation Catalyst
 - Base Metal-Coated DPF
 - US EPA Verified Emission Credit Levels
 - PM: 90% HC: 90% CO:80%
 - EPA & CARB verifications include the use of dual DPF exhaust systems for high power truck engines
 - Over 25,000 engine hours of documented field durability prior to verification

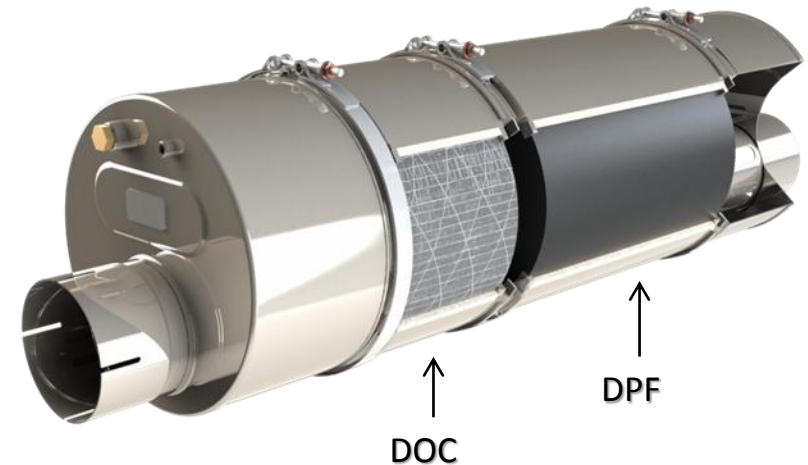

2006 Western Star Conventional Highway Tractor

- Caterpillar C15 ACERT 354kW/475hp
- Initial installation Sept 13, 2013
- Initial Odometer: 1,904,390 kms

- Filter Recovery February 6, 2015
- Odometer at Recovery: 2,213,880 kms
- Distance traveled: 309,490 kms
- DPF Engine Hour Accumulation: 4547hrs
- Summer idle: <5% / Winter idle: 20-22%
- Idled 6 nights in late Dec / Jan
- Preventative Maintenance
 - Filter de-ashing on July 4, 2014

- Truck Equipped with CPK, CDTi BPM and iAD dataloggers
- VERT VFT3 in progress at Biel





Refuse Truck



Cement Mixer



Fuel Haulage Truck

CDTi Purifilter[®] and Purifilter[®] EGR DPF under chassis installations on various buses

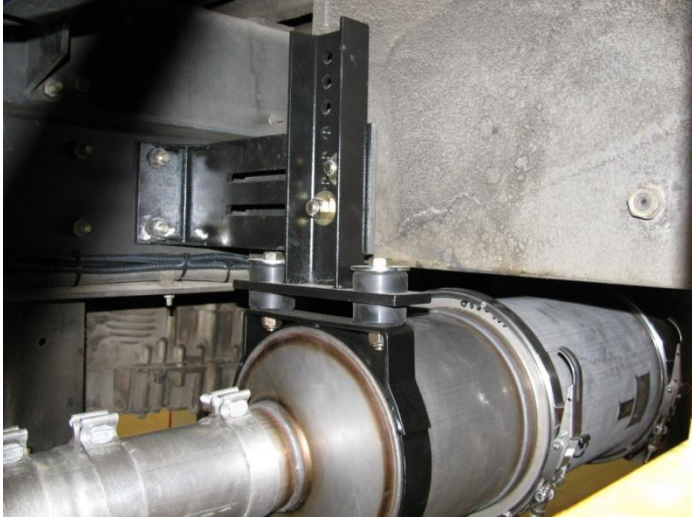

Purifilter® installation on large Highway Motorcoach



Before retrofit



After retrofit

Champagne Urbana Metropolitan Transit (Metro Chicago area)



Specialized design to fit
New Flyer transit bus-
Purifilter® EGR PCS23 with

- Recessed flanges
- Bp and Tc ports located for clearance

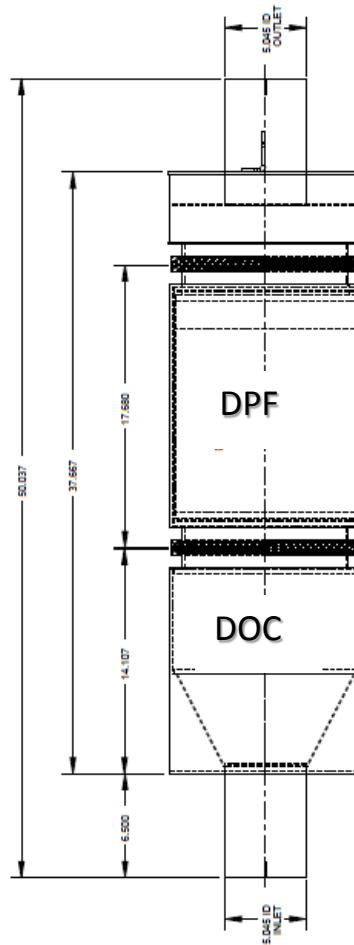

Urban Buses are typically custom built / built under license to suit local transit requirements

- In some cases, DPF's require custom design
- All retrofit candidates require inspection

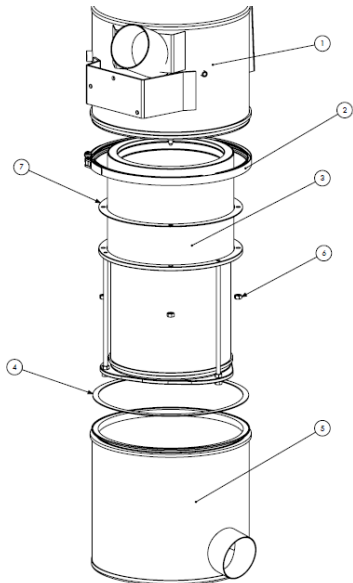
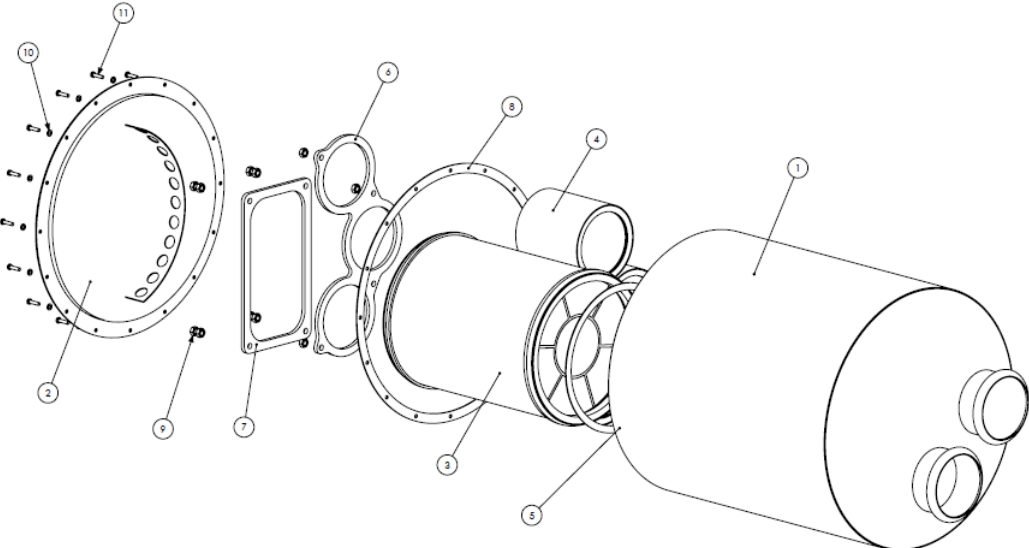
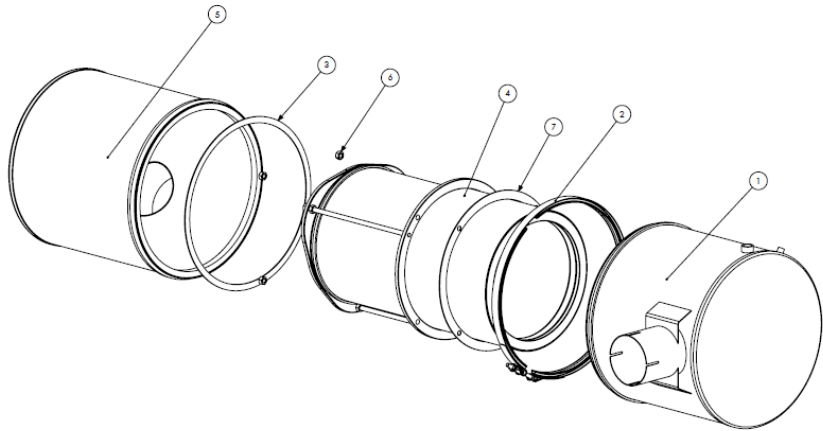
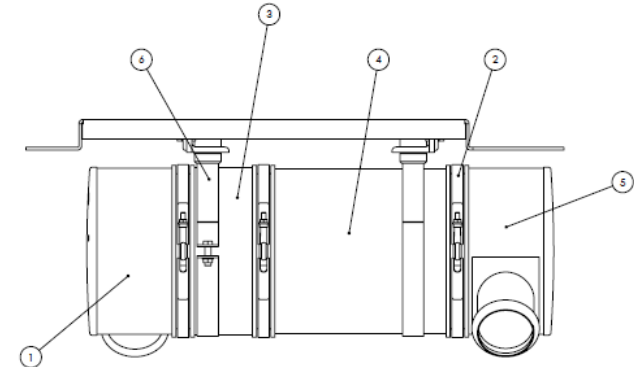



Kevin Brown

Regulatory Affairs Manager

Markham, Ontario, Canada

Office: +1 905 762 5184

Mobile: +1 905 251 5940

Email: kbrown@cdti.com

Ian MacDonald

VP Sales & Marketing

Markham, Ontario, Canada

Office: +1 905 762 5177

Mobile: +1 905 431 0410

Email: imacdonald@cdti.com

Lars Hergart

Managing Director

Malmö, Sweden

Office: +46 40 670 15 50

Mobile: +46 705 985434

Email: lhergart@cdti.com

Alain Jacques Muzart

CDTi Consultant

South America

Office: +55 19 3296 0462

Mobile: +55 19 98129 9994

Email: alain.jacques@terra.com.br

CUSTOMER SATISFACTION

- Custom Design
- Engineered Installation
- Training

